

# INSTRUCTION MANUAL

## PD-510 Pedestal Drill (240V) 32mm Drill Capacity



D600

# HAFCO METALMASTER

# DRILL PRESS

## INSTRUCTION MANUAL

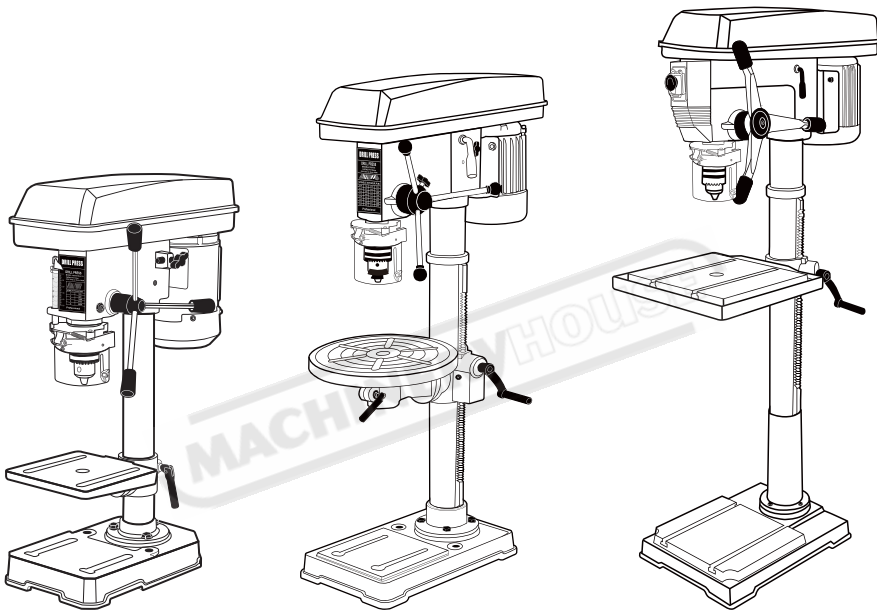

**WARNING:** Read all safety warnings and all instructions. Failure to follow the warnings and instructions may result in electric shock, fire and/or serious injury. Save all warnings and instructions for future reference.



## INTRODUCTION

Thank you for purchasing this drill press.

This machine has been designed for drilling large or small holes in metal, wood, plastic etc. Before attempting to use this product, please read this manual thoroughly and follow the instructions carefully. In doing so you will ensure the safety of yourself and that of others around you, and you can look forward to your purchase giving you long and satisfactory service.

## IMPORTANT

Please read all of the safety and operating instructions carefully before using this product. Please pay particular attention to all sections of these instructions that display warning symbols and notices.



**WARNING: THIS SYMBOL IS USED THROUGHOUT THE INSTRUCTIONS WHENEVER THERE IS A RISK OF PERSONAL INJURY. ENSURE THAT THESE WARNINGS ARE READ AND UNDERSTOOD AT ALL TIMES.**

## GENERAL SAFETY RULES



**WARNING: WHEN USING ELECTRIC TOOLS, BASIC SAFETY PRECAUTIONS SHOULD ALWAYS BE FOLLOWED TO REDUCE THE RISK OF FIRE, ELECTRIC SHOCK AND PERSONAL INJURY INCLUDING THE FOLLOWING. READ ALL THESE INSTRUCTIONS BEFORE ATTEMPTING TO OPERATE THIS PRODUCT AND SAVE THESE INSTRUCTIONS FOR FUTURE REFERENCE.**

## GENERAL SAFETY IN THE WORKPLACE

1. ALWAYS ensure that air can circulate around the machine and that the air vents are unobstructed.
2. ALWAYS keep work area clean & tidy. Cluttered work areas and benches invite accidents.
3. NEVER over-reach. Keep proper footing and balance at all times.
4. NEVER store equipment in a wet/damp environment or expose to rain.
5. KEEP other persons away. Do not let persons, especially children, not involved in the work, touch the tool or extension cable and keep them away from the work area.
6. NEVER operate a machine when under the influence of alcohol, drugs or medication.

7. ALWAYS ensure the workplace is well lit. Ensure that lighting is placed so that you will not be working in your own shadow.
8. Do not use tools in the presence of flammable liquids or gasses.
9. Stay alert, watch what you are doing, use common sense and do not operate the tool when you are tired.

## CARE OF POWER TOOLS

1. Read this manual carefully. Learn the machine applications and limitations, as well as the specific potential hazards peculiar to it.
2. ALWAYS keep guards in place and in working order. A guard or other part that is damaged should be properly repaired or replaced by an authorized service centre, unless otherwise indicated in this instruction manual.
3. Remove any adjusting keys or wrenches before starting. Form the habit of checking to ensure that keys, wrenches and tools are removed from the machine.
4. Don't force the machine and use the correct tool. It will do the job better and safer, at the rate for which it was intended.
5. ALWAYS disconnect the machine from the power supply before carrying out any servicing or changing of accessories.
6. Before further use of the tool, it should be carefully checked to determine that it will operate properly and perform its intended function. Check for alignment of moving parts, binding of moving parts, breakage of parts, mounting or other condition that may affect its operation.
7. Have defective switches repaired by an authorized service centre. Do not use a tool if the switch does not turn it on and off.
8. ALWAYS check for any damage or any condition that could affect the operation of the machine. Damaged parts should be properly repaired.
9. NEVER remove the cover panel unless the machine is disconnected from the power supply, and never use the machine with cover panels removed.
10. Have your tool repaired by a qualified person. This tool complies with the relevant safety rules. Repairs should only be carried out by qualified persons using original spare parts, otherwise this may result in considerable danger to the user.
11. NEVER use this product for any other purpose than that described in this booklet.
12. NEVER abuse the power cable by yanking the cable to disconnect it from the socket. Keep the cable away from heat, oil or sharp edges.
13. Guard against electric shock. Avoid body contact with earthed or grounded surfaces.
14. If the tool should be used outdoors, use only extension cables intended for outdoor use and marked accordingly.
15. Avoid accidental starting by making sure the power switch is off before plugging in the power cable.

## ADDITIONAL SAFETY RULES FOR DRILL PRESSES



**CAUTION: AS WITH ALL MACHINERY, THERE ARE CERTAIN HAZARDS INVOLVED WITH THEIR OPERATION AND USE. EXERCISING RESPECT AND CAUTION WILL CONSIDERABLY LESSEN THE RISK OF PERSONAL INJURY. HOWEVER, IF NORMAL SAFETY PRECAUTIONS ARE OVERLOOKED, OR IGNORED, PERSONAL INJURY TO THE OPERATOR, OR DAMAGE TO PROPERTY MAY RESULT.**

1. **IMPORTANT:** You should not operate this machine unless you are thoroughly familiar with drilling machines and drilling techniques. If there is any doubt whatsoever you should consult a qualified person.
2. **NEVER** operate the machine until it is completely assembled and you have read and understood this entire manual.
3. **ALWAYS** use clamps or a drill vice bolted to the table, to hold the work. It should never be held with bare hands.
4. **ALWAYS** shut off the power & remove drill bit before leaving the machine.
5. **ALWAYS** make all adjustments with the power off.
6. **ALWAYS** use the correct drilling speeds for the drill size and the type of material being drilled.
7. **NEVER** leave the drill unattended whilst it is running. Turn the machine **OFF** and do not leave until it has come to a complete stop.
8. **ALWAYS** remove and store the drill bits when you have finished work.
9. **NEVER** attempt to drill into a workpiece that does not have a flat surface unless a suitable support is used.
10. **ALWAYS** stop the drill before removing workpieces, work supports or swarf from the table.
11. Keep drills sharp and clean for best and safest performance. Follow instructions for changing accessories.
12. Adjust the table or depth stop to avoid drilling into the table surface.
13. **ALWAYS** be sure that the drill bit is securely locked in the chuck.
14. **NEVER** assemble or set up any work on the table while the drill is running.
15. **ALWAYS** ensure the table lock is tight before starting the drill.
16. Keep handles dry, clean and free from oil and grease.
17. **ALWAYS** keep hands and fingers away from the drill bit.



**WARNING: DUST GENERATED FROM CERTAIN MATERIALS CAN BE HAZARDOUS TO YOUR HEALTH. ALWAYS OPERATE THE DRILL IN A WELL VENTILATED AREA. USE A DUST COLLECTION SYSTEM IF POSSIBLE.**

**WARNING: THE USE OF ANY ACCESSORY OR ATTACHMENT OTHER THAN ONE RECOMMENDED IN THIS INSTRUCTION MANUAL MAY PRESENT A RISK OF PERSONAL INJURY.**

## PROTECTIVE CLOTHING

1. Dress properly. Loose clothing or other jewellery may get caught in moving parts. Non-slip footwear is recommended. Wear protective hair covering to contain long hair..
2. ALWAYS wear safety glasses. (Everyday glasses are not safety glasses.)
3. Wear a face mask if drilling into any material which produces dust.

## ELECTRICAL CONNECTIONS



**WARNING! Read these electrical safety instructions thoroughly before connecting the product to the mains supply.**

Before switching the product on, make sure that the voltage of your electricity supply is the same as that indicated on the rating plate. Connecting it to any other power source may cause damage.

This product may be fitted with a non-rewireable plug. If it is necessary to change the fuse in the plug, the fuse cover must be refitted. If the fuse cover becomes lost or damaged, the plug must not be used until a suitable replacement is obtained.

If the plug has to be changed because it is not suitable for your socket, or due to damage, it should be cut off and a replacement fitted, following the wiring instructions shown below. The old plug must be disposed of safely, as insertion into a mains socket could cause an electrical hazard.

# PRODUCT OVERVIEW

## BENCH DRILL

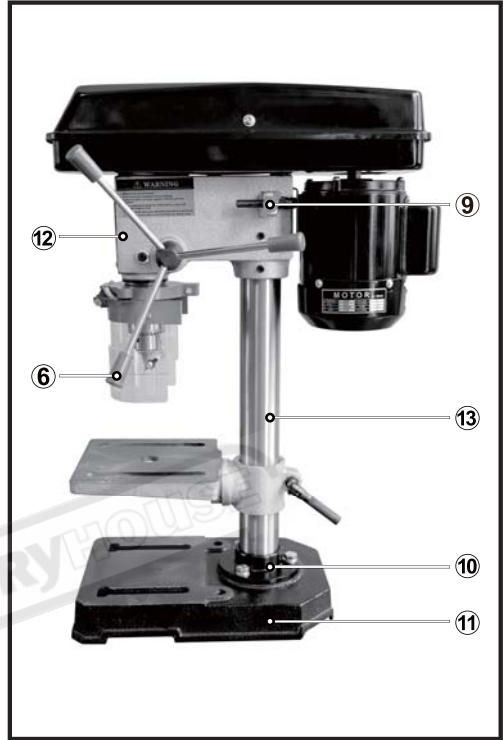
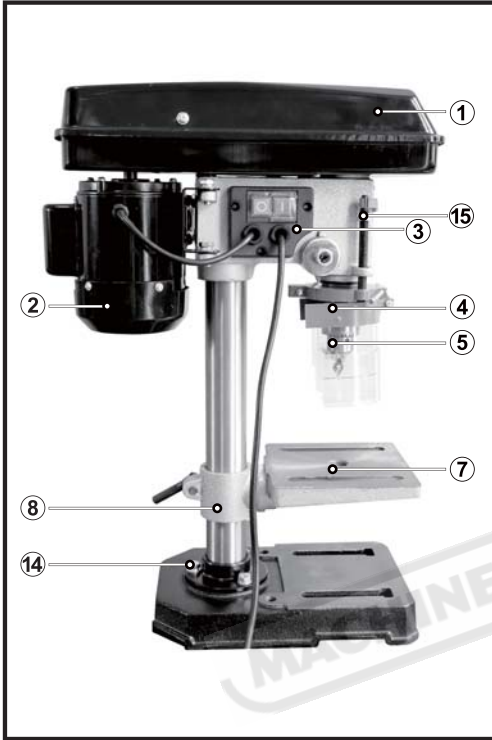

①	Pulley Cover	⑦	Table	⑬	Column
②	Motor	⑧	Table Holder	⑭	Bolts
③	Switch	⑨	Belt Tension Lock knob	⑮	Depth Stop Lock Nuts
④	Chuck guard	⑩	Column Support		
⑤	Chuck	⑪	Base		
⑥	Feed Handle	⑫	Main Housing		

# PEDESTAL DRILL

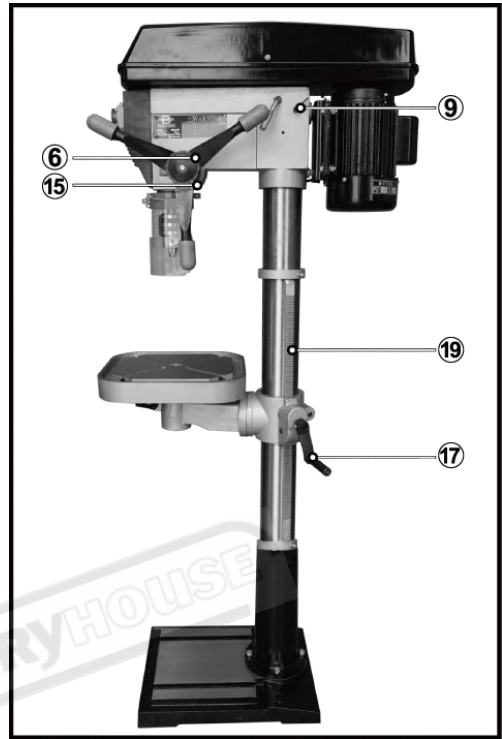
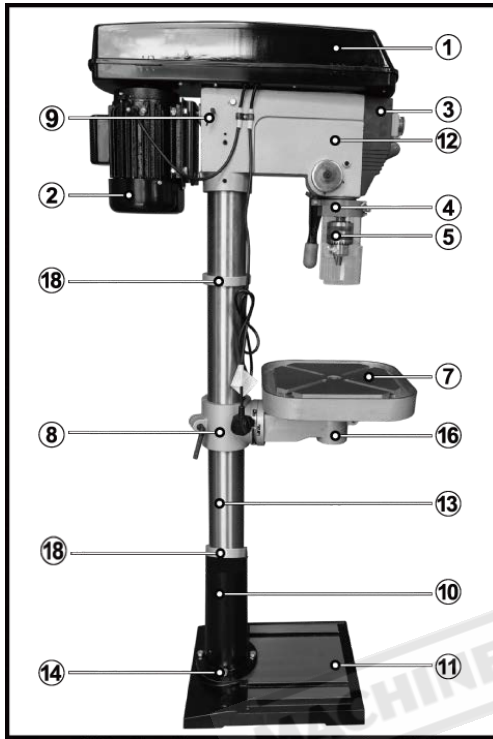

①	Pulley Cover	⑧	Table Holder	⑮	Depth Stop Lock Knob
②	Motor	⑨	Belt Tension Lock knob	⑯	Table Lock
③	Switch	⑩	Column Support	⑰	Table Adjustment Handle
④	Chuck guard	⑪	Base	⑱	Rack Collar
⑤	Chuck	⑫	Main Housing		Rack
⑥	Feed Handle	⑬	Column		
⑦	Table	⑭	Bolts		

## UNPACKING

The drill press is delivered with the components shown last page. Check the parts against the above list. Should there be any deficiencies or damage, you should contact your dealer immediately where the product was originally purchased. Do not discard the packaging until the machine is assembled. The packaging consists of cardboard and appropriately marked materials which can be sent to a re-cycling facility.

To protect the machine parts from moisture, a protective coating of light machine oil will have been applied to the outside surfaces. Remove any excess with a paper towel.

Take care when lifting the head assembly, considering its weight.

Before use, the machine must be mounted, and securely bolted, to a strong, heavy workbench, of sufficient height that you will be standing upright when working.

Ensure the work place is adequately lit, and that you will not be working in your own shadow.

## ASSEMBLY



**WARNING!** During assembly ensure the drill press is disconnected from the power supply.

Carefully remove contents from the packing box.

Select a firm, level surface on which to assemble the drill press.

### BASE & COLUMN

1. Select the base (Fig. 1) and align the column support over the large hole (Fig. 2).
2. Align the holes in the column support with those in the base and secure in place using the bolts and washers. Using a spanner securely tighten all bolts (Fig. 3).
3. We recommend mounting the base to a stable surface for proper support.
4. Slide the column into the column support (Fig. 4).



- Secure in place with 2 grub screws using the hex key (Fig. 5).

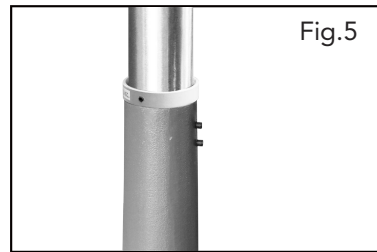

Fig.5

## RACK & TABLE

- Slide one of the rack collars, tapered side facing up, over the column until it reaches the column support (Fig. 5).  
*Note: For Pedestal drill PD-325(D592), PD-360(D596), PD-440(D598), PD-510(D600) Only.*

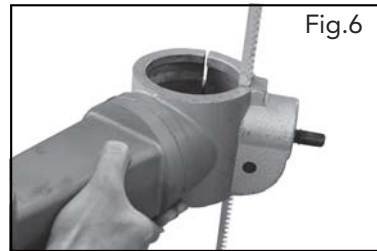

Fig.6

- Install the rack into the table support as shown (Fig. 6).

- Assemble the support and rack onto the column, ensuring the rack is positioned on the right side of the column (when viewing the product from the front) (Fig. 7).



Fig.7

- Slide the rack all the way down until it locates into the lower column support (Fig. 8). Slide the collar, tapered side facing down, over the column until it locates the rack. Tighten the grub screw on upper collar (Fig.9).



Fig.8



Fig.9

- Fix table adjustment handle on the support (Fig. 10).



Fig.10

- Assemble table onto table support, tighten in place with table lock (Fig. 11).



## MAIN HOUSING

- Lift the main housing and slide it down onto the column as far as it will go (Fig. 12). Before securing the housing, ensure the spindle aligns with the table and base.



- To secure in position tighten the grub screws on the left and right hand sides of the housing (Fig. 13).



- To fit the feed wheel handles, screw them into feed wheel hub (Fig. 14).



- For some cast iron feed handle, tighten the 3 grub screws to wheel hub (Fig.15) then fix the plastic case on cast iron feed handle as shown Fig. 16.

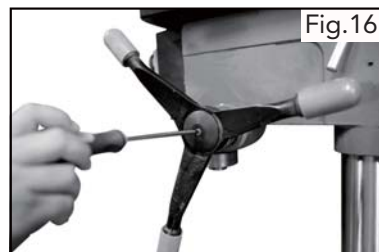

## CHUCK & ARBOR

1. Before any assembly, ensure the chuck jaws are wound all the way up (inside the chuck) to prevent them from damage (Fig. 17).



2. Tighten Philip's head screws of the chuck guard to quill shaft (Fig. 18).



3. Fit the tapered arbor end into the chuck by hand, using reasonable fore (Fig. 19).



4. The arbor can then be inserted into the quill, twisting the arbor as you insert, aligning the tang into the slot. It should fit in with little resistance (Fig. 20).



5. Once it is located a firm tap on the underside of the chuck with a soft hammer is required to secure it. The chuck & arbor are installed correctly if they cannot be pulley out with hand force (Fig. 21).



## SETTINGS AND AJUSTEMENTS



**WARNING!** During settings and adjustments ensure the drill press is disconnected from the power supply.

### TABLE HEIGHT ADJUSTMENT

1. Loosen the table support lock (Fig. 22).



2. Rotate the table adjustment handle to set the desired table height and tighten the table rock to secure the table in position (Fig. 23).



### TABEL BEVEL ADJUSTMENT

1. The bevel angel is adjusted by loosening the bolt that is located underneath table support with a spanner (Fig. 24).



2. After tilting the working table (Fig. 25) to appropriate position, re-tighten the bolt to secure its position.



**CAUTION:** When the table is angled/tilted, ensure the workpiece is clamped to the table.

## INSTALLING STRAIGHT SHANK DRILL BITS



1. Using the chuck key, loosen the jaws of the chuck by rotating in an anti-clockwise direction (Fig. 26).



Fig.26

2. Insert the drill bit into the chuck (Fig. 27).



Fig.27

3. Whilst holding the drill bit in one hand rotate the top collar of the chuck in a clockwise direction. Insert the chuck key into 1 of the 3 rotating holes and tighten until drill bit is secure (Fig. 28).



Fig.28

## MORSE TAPER DRILL BITS



To use Morse taper bits, remove chuck and arbor.

1. Turn arbor until the tang aligns with the slot in the quill (Fig. 29).



Fig.29

2. Insert the drift key into the slot and tap firmly with a metal hammer until it releases. (Ensure the chuck jaws are wound all the way up to prevent damage (Fig. 30).

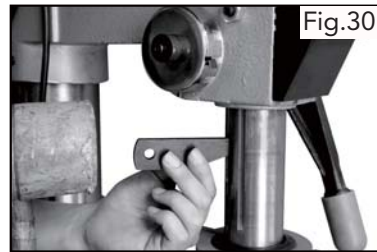

3. Place taper bit into the spindle hole, twisting and pushing upward until bit is snug (Fig. 31).



4. Place block of wood on the table and raise up table until the tapered bit is firmly into the spindle.

## PRE-SETTING THE DRILLING DEPTH

### BENCH TYPE

To set the depth of the hole, adjust the depth stop as follows:

1. Lower the chuck with the power OFF, until the drill bit touches the surface of the workpiece, and hold in that position.
2. Spin down the adjuster nut so that the gap between its underside and top of bracket is the depth of the hole required. Screw down the lock nut and lock it against the adjuster nut.



The drill is now set to drill holes to your pre-determined depth from that particular start point. i.e. Providing the surface of your workpiece is flat and level, you may drill a series of holes, each to the same depth.

The scale and pointer can be used when drilling individual holes.

Lower the chuck until the drill bit touches the work, set the pointer against a point on the scale, and proceed to drill to the required depth, using the scale.

## FLOOR TYPE

To stop spindle (and bit) at a desired depth:

1. Loosen depth stop lock knob by turning in an anti-clockwise direction (Fig. 33).
2. Rotate depth scale to the desired depth, then tighten half wing bolt (Fig. 34).



To hold the spindle (and bit) at a desired depth:

1. Loosen depth stop lock knob, turn feed wheel handle to lowest point (Fig.35).
2. Rotate depth scale to desired depth and re-tighten depth stop lock knob. This will hold assembly stationery at desired depth.



## CHANING THE SPEED

### BENCH TYPE

Before changing the speeds, ensure the machine is switched OFF, and disconnected from the power supply.

1. Open the pulley cover.
2. Slacken off the belt tension locking knob, to relieve any tension on the drive belt.
3. Consult the chart inside the pulley cover, and position the belt on the pulley's according to the spindle speed required.
4. When the belt has been correctly positioned, re-tension by levering the motor, with its bracket, away from the head, so that tension is applied to the belt. Tension is correct when the belt deflects by approx.  $\frac{1}{2}$ " at its centre, when using reasonable thumb pressure. Lock the motor in this position using the locking knob.



## FLOOR TYPE

The speed of the drill press can be changed by adjusting the belt on the pulley system. See chart inside pulley cover for speed configurations.

1. Release the belt tension locking knobs located on either side of the main housing (Fig.37).

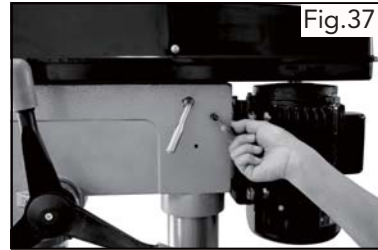

2. Once the tension is released, the belt tension handle can be used to move the motor pulley closer to the idler pulley (Fig.38).



3. The belt is removed by lifting it over the lip of the pulley while rotating the pulley simultaneously (Fig.39).



4. After re-adjusting the belts, use the belt tension handle to move the motor pulley further away from the idler pulley. When the desired position is achieved use the locking knobs to secure the pulleys in place (Fig.40)



5. Proper belt tension is achieved when the measured deflection (by pushing in the centre of the belt) is approx. 5mm (Fig. 41).



## OPERATION

### TURNING ON AND OFF

**Note:** The pulley cover must be closed to operate the drill press.

1. Switch the drill press On by pressing the green(I) button on the switch (Fig.42-43).
2. Switch the drill press Off by pressing the red(O) button on the switch.
3. Secure your workpiece to the table if possible, use a vice or clamps.

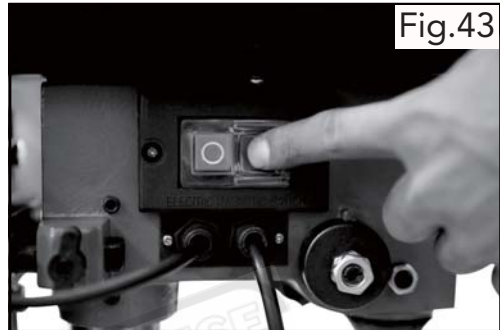
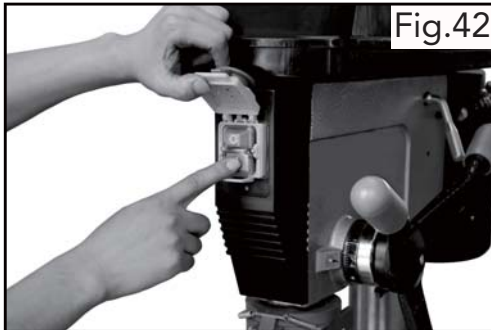

### DRILLING

1. Ensure the drill press is switched off and disconnected from the power supply.
2. Loosen the jaws of the chuck with the chuck key by turning in an anti-clockwise direction and insert the selected drill bit into the as far as it will go.
3. Insert the chuck key into 1 of the 3 locating holes and tighten until drill bit is secure.
4. Select your drilling depth and secure the depth stop lock knob in position.
5. Adjust the table to your desired position.
6. Slowly rotate the feed wheel handles to bring the drill bit down towards the table and into your workpiece. After drilling a hole, release the feed wheel handles slowly to return the chuck to its original position.
7. Continue the operation until the task is completed. When completed, switch the drill press Off by pressing the red (O) button on the switch.

### MAINTENANCE

For maximum performance, it is essential that the Drill Press is properly maintained. Always inspect it before use. Any damage should be repaired, and faults rectified. Always remove the plug from the power supply before carrying out any adjustment, servicing or maintenance.

Please refer to the trouble shooting chart on pages down. If you are unable to rectify any faults, please contact your local dealer for assistance.

## MONTHLY (IF IN REGULAR USE)

1. Check tightness of mounting bolts, and head and column securing set screws.
  2. Check the drive belt for wear, and replace if frayed or damaged.
  3. Blow out with compressed air, or vacuum clean out, any dust that may have accumulated in the motor fan vents.
  4. Apply a thin coat of wax paste or light oil to the table and column, for lubrication, and to help prevent corrosion.
- If the mains lead is damaged in any way, it should be replaced immediately.

## LUBRICATION

All bearings are packed with grease at the factory and require no further lubrication.

Occasionally, lubricate the quill shaft assembly and rack with light oil if required.



## AFTER USE

Remove all swarf from the machine and thoroughly clean all surfaces.

Components should be kept dry, with machined surfaces lightly oiled.

Always remove drill bits, and store in a safe place.

## TROUBLE SHOOTING

PROBLEM	PROBABLE CAUSE	REMEDY
Noisy operation (under load).	a. Incorrect belt tension. b. Dry spindle. c. Loose pulley. d. Loose belt. e. Worn bearing.	a. Adjust tension. b. Remove spindle and quill assembly and lubricate. c. Tighten pulley. d. Adjust belt tension. e. Replace bearing.
Excessive drill wobble.	a. Loose chuck. b. Worn spindle or bearing. c. Worn chuck. d. Bent drill bit.	a. Tighten by pressing chuck down on to a block of wood against the table. b. Replace spindle shaft or bearing. c. Replace chuck. d. Renew drill bit.
Motor won't start.	a. Power supply. b. Motor connection. c. Switch connection faulty. d. Faulty switch. e. Motor windings burned. f. Pulley cover not closed. g. Micro switch on cover not operating.***	a. Check power cord/fuse. b. Check motor connections. c. Check switch connections. d. Replace switch. e. Replace motor. f. Close pulley cover. g. Check operation of micro switch, and renew/adjust as necessary.
Drill binds in workpiece.	a. Excessive feed pressure. b. Loose belt. c. Loose drill. d. Incorrect bit speed. e. Drill angles incorrect for type of material.	a. Apply less pressure. b. Check belt tension. c. Tighten drill with key. d. Adjust the drill speed reasonably. e. Consult a technical manual dealing with materials, drills and cutting angles, and sharpen drill accordingly.
Drill bit burns or smokes.	a. Incorrect speed. b. Swarf is not discharging. c. Dull drill or not proper clearance for material. d. Needs coolant. e. Excessive feed pressure	a. Adjust drill speed accordingly. b. Clean drill. c. Check sharpness & taper. d. Use coolant whilst drilling. e. Apply less pressure.
Table difficult to raise.	a. Needs lubrication. b. Table lock tightened.	a. Lubricate with light oil. b. Loosen clamp.

## ENVIRONMENTAL PROTECTION



Power tools that are no longer usable should not be disposed with household waste but in an environmentally friendly way. Please recycle where facilities exist. Check with your local council authority for recycling advice.



Recycling packaging reduces the need for landfill and raw materials. Reuse of recycled material decreases pollution in the environment. Please recycle packaging where facilities exist. Check with your local council authority for recycling advice.

MACHINERYHOUSE

EXPLODED DIAGRAM OF DRILL PRESS BD-325 ( D590 )

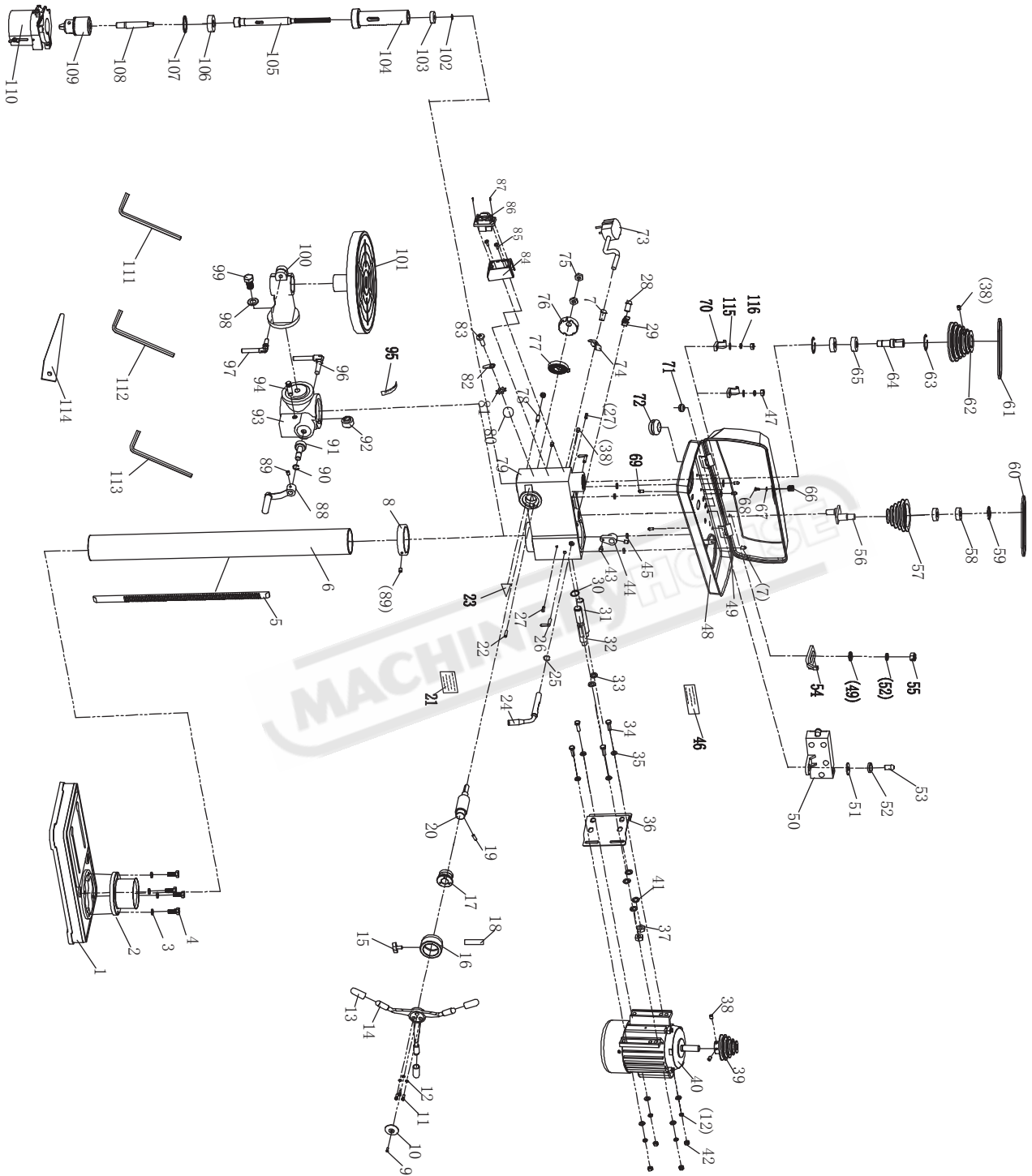

1	BASE
2	COLUMN FLANGE
3	SPRING WASHER
4	OUTSIDE HEX. BOLT
5	RACK
6	COLUMN
7	CROSS RECESS PAN HD SCREW
8	COLLAR RACK
9	CROSS RECESS COUNTERSUNK HD SCREW
10	CAP HANDLE
11	HEX. SOC HD CAP SCREW
12	SPRING WASHER
13	HANDLE SHEATH
14	HANDLE
15	WING KNOB
16	DIAL SCALE
17	CONNECTION LOOP
18	CALIBRATION LABEL
19	ROLL PIN
20	GEAR SHAFT
21	WARNING LABEL
22	ROLL PIN
23	INDICATOR
24	HANDLE BELT TENSION
25	CIRCLIP FOR BEARING
26	LOCKING HANDLE KNOB
27	ROLL PIN
28	CROSS RECESSED PAN HEAD SCREW
29	HOOP FOR KEY WRENCH
30	CIRCLIP FOR BEARING
31	SLIP SHAFT
32	ADJUSTING SHAFT
33	FLAT WASHER
34	OUTSIDE HEX. BOLT
35	FLAT WASHER
36	MOTOR CONNECTION PLATE
37	NUT
38	HEX. SOC SET SCREW
39	MOTOR PULLEY

40	MOTOR
41	SPRING WASHER
42	NUT
43	CAM PIN
44	CAM
45	DAMPING WASHER
46	SPEED LABEL
47	NUT
48	PULLEY COVER
49	FLAT WASHER
50	MICRO SWITCH BOX
51	BIG FLAT WASHER
52	SPRING WASHER
53	CROSS RECESSED PAN HEAD SCREW
54	MICRO SWITCH PRESSING CLAW
55	NUT
56	ECCENTRIC SHAFT
57	MIDDLE PULLEY
58	BEARING
59	CIRCLIP FOR HOLE
60	BELT
61	BELT
62	SPINDLE PULLEY
63	CIRCLIP FOR HOLE
64	KEYWAY SPINDLE
65	BEARING
66	PULLEY COVER KNOB
67	BIG FLAT WASHER
68	CROSS RECESSED PAN HEAD SCREW
69	CROSS RECESSED PAN HEAD SCREW
70	CORD CLAMP
71	PROTECTOR RING
72	PROTECTOR RING
73	PLUG WITH CABLE
74	CORD CLAMP
75	NUT
76	SPRING COVER
77	SPRING
78	A WORD HEAD SCREW

79	HOUSING
80	LABEL
81	TOOTH LOCK WASHER
82	GROUNDED PARTS
83	CROSS RECESS HEAD SCREW
84	SWITCH BOX
85	CROSS RECESS HEAD SCREW
86	SWITCH
87	CROSS RECESS HEAD TAPPING SCREW
88	CRANK
89	HEX. SOC SET SCREW
90	CIRCLIP FOR BEARING
91	WORM
92	WORM GEAR
93	TABLE SUPPORT
94	WORM PIN
95	ANGLE LABEL
96	LOCKING HANDLE
97	LOCKING HANDLE
98	SPRING WASHER
99	OUTSIDE HEX. BOLT
100	TABLE ARM
101	WORKING TABLE
102	CIRCLIP FOR BEARING
103	BEARING
104	SPINDLE SOCKET
105	MAIN SPINDLE
106	BEARING
107	WASHER
108	TAPER SPINDLE
109	CHUCK
110	CHUCK GUARD
111	HEXAGON BAR WRENCH
112	HEXAGON BAR WRENCH
113	HEXAGON BAR WRENCH
114	THICK BRAKE IRON
115	FLAT WASHER
116	SPRING WASHER

EXPLODED DIAGRAM OF DRILL PRESS PD-325 ( D592 )

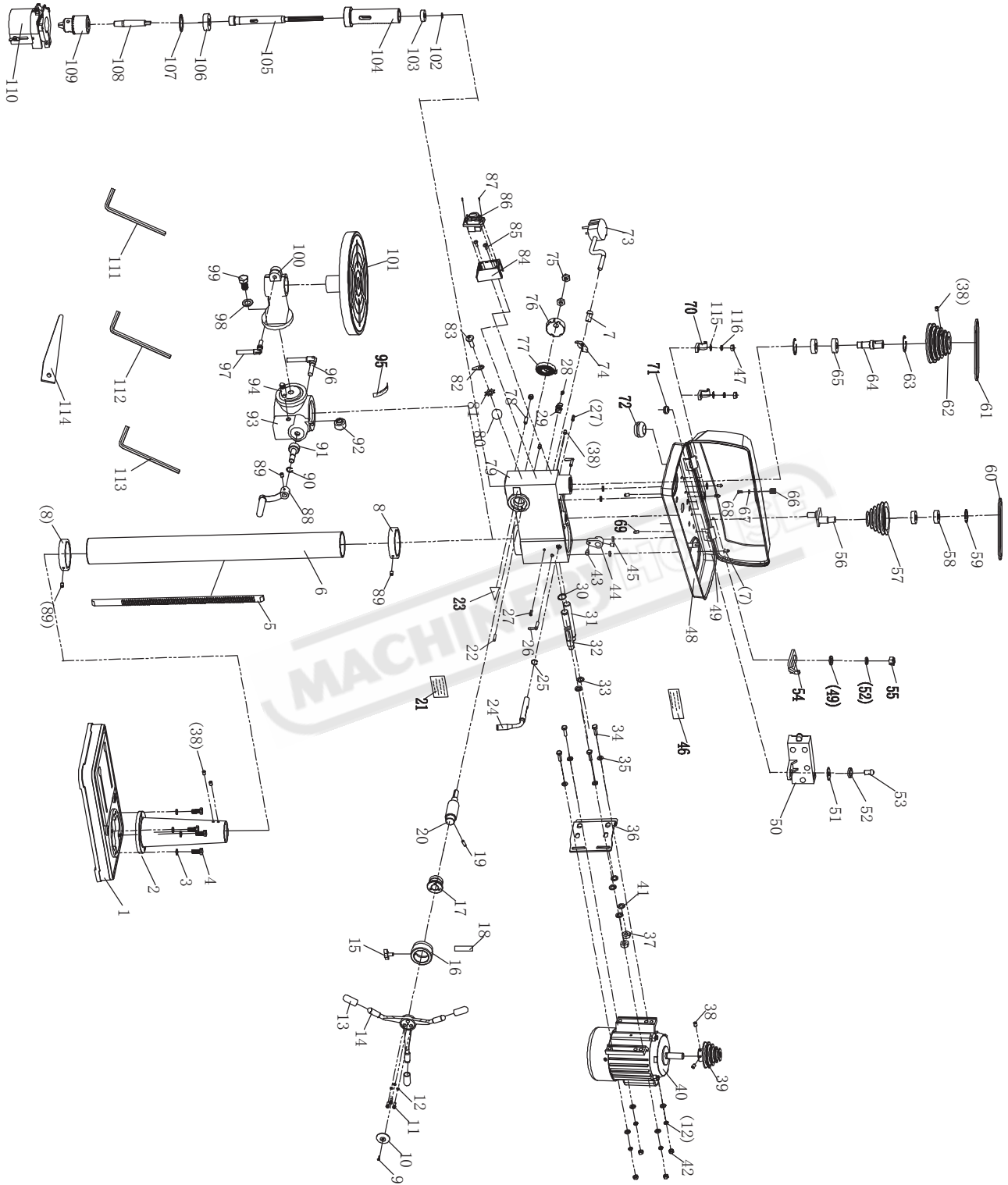

1	BASE
2	COLUMN FLANGE
3	SPRING WASHER
4	OUTSIDE HEX. BOLT
5	RACK
6	COLUMN
7	CROSS RECESS PAN HD SCREW
8	COLLAR RACK
9	CROSS RECESS COUNTERSUNK HD SCREW
10	CAP HANDLE
11	HEX. SOC HD CAP SCREW
12	SPRING WASHER
13	HANDLE SHEATH
14	HANDLE
15	WING KNOB
16	DIAL SCALE
17	CONNECTION LOOP
18	CALIBRATION LABEL
19	ROLL PIN
20	GEAR SHAFT
21	WARNING LABEL
22	ROLL PIN
23	INDICATOR
24	HANDLE BELT TENSION
25	CIRCLIP FOR BEARING
26	LOOKING HANDLE KNOB
27	ROLL PIN
28	CROSS RECESSED PAN HEAD SCREW
29	HOOP FOR KEY WRENCH
30	CIRCLIP FOR BEARING
31	SLIP SHAFT
32	ADJUSTING SHAFT
33	FLAT WASHER
34	OUTSIDE HEX. BOLT
35	FLAT WASHER
36	MOTOR CONNECTION PLATE
37	NUT
38	HEX. SOC SET SCREW
39	MOTOR PULLEY

40	MOTOR
41	SPRING WASHER
42	NUT
43	CAM PIN
44	CAM
45	DAMPING WASHER
46	SPEED LABEL
47	NUT
48	PULLEY COVER
49	FLAT WASHER
50	MICRO SWITCH BOX
51	BIG FLAT WASHER
52	SPRING WASHER
53	CROSS RECESSED PAN HEAD SCREW
54	MICRO SWITCH PRESSING CLAW
55	NUT
56	ECCENTRIC SHAFT
57	MIDDLE PULLEY
58	BEARING
59	CIRCLIP FOR HOLE
60	BELT
61	BELT
62	SPINDLE PULLEY
63	CIRCLIP FOR HOLE
64	KEYWAY SPINDLE
65	BEARING
66	PULLEY COVER KNOB
67	BIG FLAT WASHER
68	CROSS RECESSED PAN HEAD SCREW
69	CROSS RECESSED PAN HEAD SCREW
70	CORD CLAMP
71	PROTECTOR RING
72	PROTECTOR RING
73	PLUG WITH CABLE
74	CORD CLAMP
75	NUT
76	SPRING COVER
77	SPRING
78	A WORD HEAD SCREW

79	HOUSING
80	LABEL
81	TOOTH LOCK WASHER
82	GROUND PARTS
83	CROSS RECESS HEAD SCREW
84	SWITCH BOX
85	CROSS RECESS HEAD SCREW
86	SWITCH
87	CROSS RECESS HEAD TAPPING SCREW
88	CRANK
89	HEX. SOC SET SCREW
90	CIRCLIP FOR BEARING
91	WORM
92	WORM GEAR
93	TABLE SUPPORT
94	WORM PIN
95	ANGLE LABEL
96	LOCKING HANDLE
97	LOCKING HANDLE
98	SPRING WASHER
99	OUTSIDE HEX. BOLT
100	TABLE ARM
101	WORKING TABLE
102	CIRCLIP FOR BEARING
103	BEARING
104	SPINDLE SOCKET
105	MAIN SPINDLE
106	BEARING
107	WASHER
108	TAPER SPINDLE
109	CHUCK
110	CHUCK GUARD
111	HEXAGON BAR WRENCH
112	HEXAGON BAR WRENCH
113	HEXAGON BAR WRENCH
114	THICK BRAKE IRON
115	FLAT WASHER
116	SPRING WASHER

EXPLODED DIAGRAM OF DRILL PRESS BD-360 ( D594 )

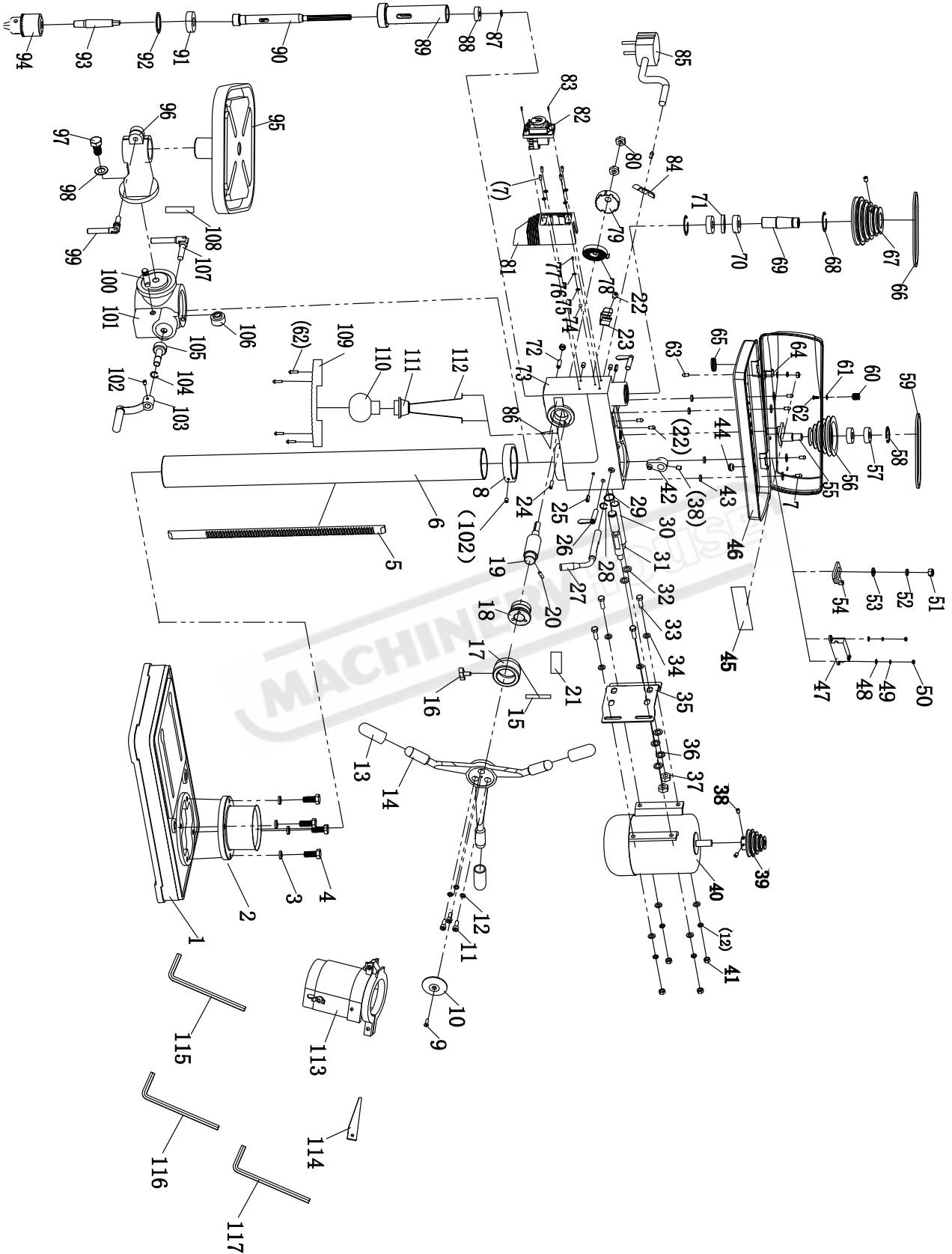

1	BASE
2	COLUMN FLANGE
3	SPRING WASHER
4	OUTSIDE HEX. BOLT
5	RACK
6	COLUMN
7	CROSS RECESS PAN HD SCREW
8	COLLAR RACK
9	CROSS RECESS COUNTERSUNK HD SCREW
10	CAP HANDLE
11	HEX. SOC HD CAP SCREW
12	SPRING WASHER
13	HANDLE SHEATH
14	HANDLE
15	CALIBRATION LABEL
16	WING KNOB
17	DIAL SCALE
18	CONNECTION LOOP
19	GEAR SHAFT
20	ROLL PIN
21	WARNING LABEL
22	CROSS RECESSED PAN HEAD SCREW
23	HOOP FOR KEY WRENCH
24	ROLL PIN
25	ROLL PIN
26	LOCKING HANDLE KNOB
27	HANDLE BELT TENSION
28	CIRCLIP FOR BEARING
29	CIRCLIP FOR BEARING
30	SLIP SHAFT
31	ADJUSTING SHAFT
32	FLAT WASHER
33	OUTSIDE HEX. BOLT
34	FLAT WASHER
35	MOTOR CONNECTION PLATE
36	SPRING WASHER
37	NUT
38	HEX. SOC SET SCREW
39	MOTOR PULLEY

40	MOTOR
41	NUT
42	CAM ASSEMBLY
43	DAMPING WASHER
44	PROTECTOR RING
45	SPEED LABEL
46	PULLEY COVER
47	MICRO SWITCH
48	FLAT WASHER
49	SPRING WASHER
50	NUT
51	NUT
52	SPRING WASHER
53	FLAT WASHER
54	MICRO SWITCH PRESSING CLAW
55	ECCENTRIC SHAFT
56	MIDDLE PULLEY
57	BEARING
58	CIRCLIP FOR HOLE
59	BELT
60	PULLEY COVER KNOB
61	BIG FLAT WASHER
62	CROSS RECESSED PAN HEAD SCREW
63	CROSS RECESSED PAN HEAD SCREW
64	CORD CLAMP
65	PROTECTOR RING
66	BELT
67	SPINDLE PULLEY
68	CIRCLIP FOR HOLE
69	KEYWAY SPINDLE
70	BEARING
71	BEARING RING
72	A WORD HEAD SCREW
73	HOUSING
74	LABEL
75	TOOTH LOCK WASHER
76	GROUNDDED PARTS
77	CROSS RECESS HEAD SCREW
78	SPRING

79	SPRING COVER
80	THIN NUT
81	SWITCH BOX
82	SWITCH
83	CROSS RECESS HEAD TAPPING SCREW
84	CORD CLAMP
85	PLUG WITH CABLE
86	INDICATOR
87	CIRCLIP FOR BEARING
88	BEARING
89	SPINDLE SOCKET
90	MAIN SPINDLE
91	BEARING
92	WASHER
93	TAPER SPINDLE
94	CHUCK
95	WORKING TABLE
96	TABLE ARM
97	OUTSIDE HEX BOLT
98	SPRING WASHER
99	LOCKING HANDLE
100	WORM PIN
101	TABLE SUPPORT
102	HEX. SOC SET SCREW
103	CRANK
104	CIRCLIP FOR BEARING
105	WORM
106	WORM GEAR
107	LOCKING HANDLE
108	ANGLE LABEL
109	LAMP-CHIMNEY
110	LAMP-BULB
111	LAMP-SOCKET
112	LAMP-BRACKET
113	CHUCK GUARD
114	THICK BRAKE IRON
115	HEXAGON BAR WRENCH
116	HEXAGON BAR WRENCH
117	HEXAGON BAR WRENCH

EXPLODED DIAGRAM OF DRILL PRESS PD-360 ( D596 )

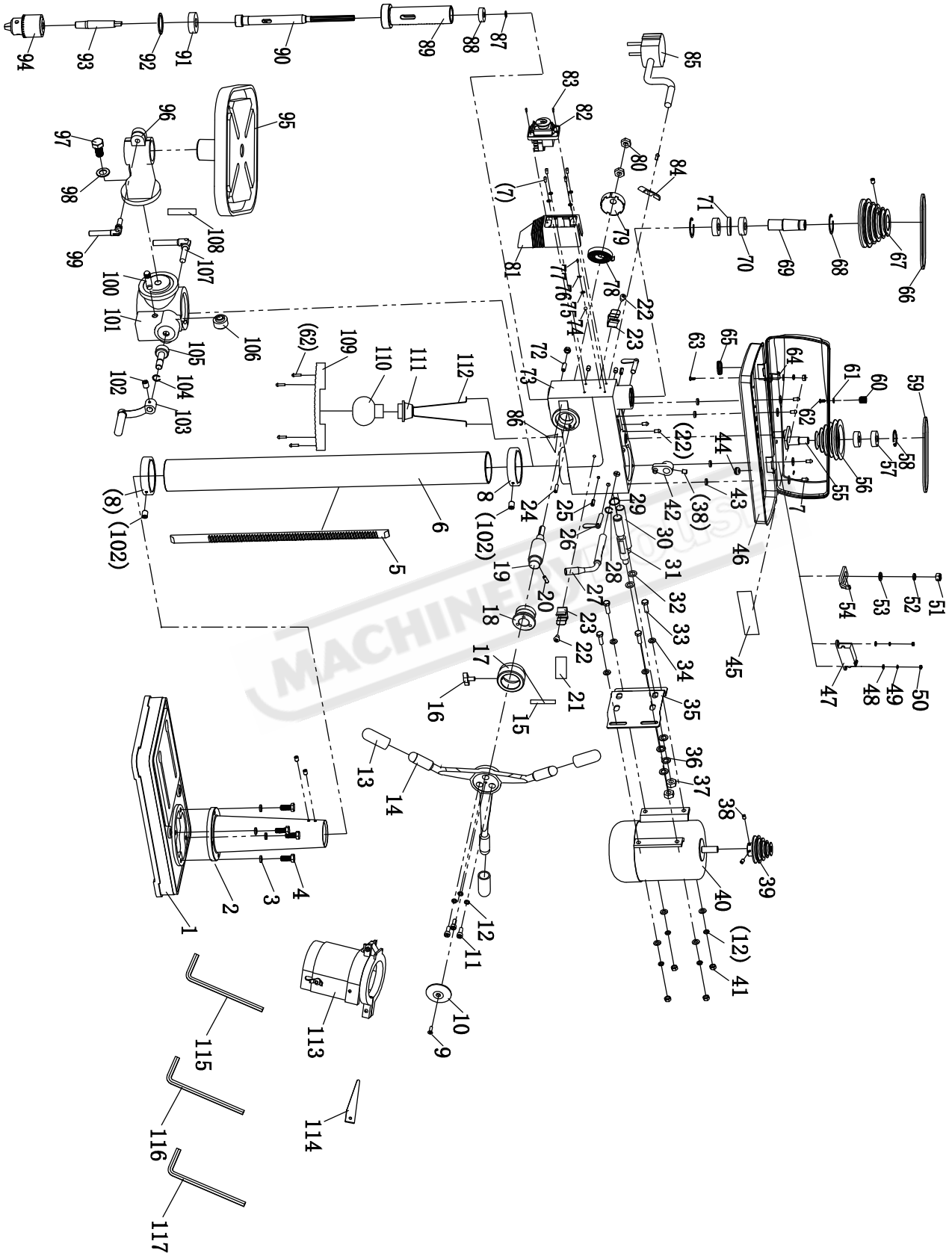

1	BASE
2	COLUMN FLANGE
3	SPRING WASHER
4	OUTSIDE HEX. BOLT
5	RACK
6	COLUMN
7	CROSS RECESS PAN HD SCREW
8	COLLAR RACK
9	CROSS RECESS COUNTERSUNK HD SCREW
10	CAP HANDLE
11	HEX. SOC HD CAP SCREW
12	SPRING WASHER
13	HANDLE SHEATH
14	HANDLE
15	CALIBRATION LABEL
16	WING KNOB
17	DIAL SCALE
18	CONNECTION LOOP
19	GEAR SHAFT
20	ROLL PIN
21	WARNING LABEL
22	CROSS RECESSED PAN HEAD SCREW
23	HOOP FOR KEY WRENCH
24	ROLL PIN
25	ROLL PIN
26	WING KNOB
27	HANDLE BELT TENSION
28	CIRCLIP FOR BEARING
29	CIRCLIP FOR BEARING
30	SLIP SHAFT
31	ADJUSTING SHAFT
32	FLAT WASHER
33	OUTSIDE HEX. BOLT
34	FLAT WASHER
35	MOTOR CONNECTION PLATE
36	SPRING WASHER
37	N U T
38	HEX. SOC SET SCREW
39	MOTOR PULLEY

40	MOTOR
41	N U T
42	CAM ASSEMBLY
43	DAMPING WASHER
44	PROTECTOR RING
45	SPEED LABEL
46	PULLEY COVER
47	MICRO SWITCH
48	FLAT WASHER
49	SPRING WASHER
50	NUT
51	NUT
52	SPRING WASHER
53	FLAT WASHER
54	MICRO SWITCH PRESSING CLAW
55	ECCENTRIC SHAFT
56	MIDDLE PULLEY
57	BEARING
58	CIRCLIP FOR HOLE
59	BELT
60	PULLEY COVER KNOB
61	BIG FLAT WASHER
62	CROSS RECESSED PAN HEAD SCREW
63	CROSS RECESSED PAN HEAD SCREW
64	CORD CLAMP
65	PROTECTOR RING
66	BELT
67	SPINDLE PULLEY
68	CIRCLIP FOR HOLE
69	KEYWAY SPINDLE
70	BEARING
71	BEARING RING
72	A WORD HEAD SCREW
73	HOUSING
74	LABEL
75	TOOTH LOCK WASHER
76	GROUNDIED PARTS
77	CROSS RECESS HEAD SCREW
78	SPRING

79	SPRING COVER
80	THIN NUT
81	SWITCH BOX
82	SWITCH
83	CROSS RECESS HEAD TAPPING SCREW
84	CORD CLAMP
85	PLUG WITH CABLE
86	INDICATOR
87	CIRCLIP FOR BEARING
88	BEARING
89	SPINDLE SOCKET
90	MAIN SPINDLE
91	BEARING
92	WASHER
93	TAPER SPINDLE
94	CHUCK
95	WORKING TABLE
96	TABLE ARM
97	OUTSIDE HEX BOLT
98	SPRING WASHER
99	LOCKING HANDLE
100	WORM PIN
101	TABLE SUPPORT
102	HEX. SOC SET SCREW
103	CRANK
104	CIRCLIP FOR BEARING
105	WORM
106	WORM GEAR
107	LOCKING HANDLE
108	ANGLE LABEL
109	LAMP-CHIMNEY
110	LAMP-BULB
111	LAMP-SOCKET
112	LAMP-BRACKET
113	CHUCK GUARD
114	THICK BRAKE IRON
115	HEXAGON BAR WRENCH
116	HEXAGON BAR WRENCH
117	HEXAGON BAR WRENCH



**EXPLODED DIAGRAM OF DRILL PRESS PD-440 ( D598 )**

1	BASE
2	COLUMN FLANGE
3	SPRING WASHER
4	OUTSIDE HEX. BOLT
5	CRANK
6	HEX. SOC SET SCREW
7	CIRCLIP FOR BEARING
8	WORM
9	TABLE SUPPORT
10	WORM PIN
11	WORKING TABLE
12	SPRING WASHER
13	OUTSIDE HEX. BOLT
14	RUBBER BLANKET
15	LOCKING HANDLE
16	ANGLE LABEL
17	WORM GEAR
18	COLUMN
19	RACK
20	CROSS RECESS PAN HD SCREW
21	LAMP-CHIMNEY
22	LAMP-BULB
23	LAMP-SOCKET
24	LAMP-BRACKET
25	COLLAR RACK
26	CROSS RECESS PAN HD SCREW
27	HANDLE SHEATH
28	CROSS RECESS COUNTERSUNK HD SCREW
29	CAP HANDLE
30	HEX. SOC HD CAP SCREW
31	SPRING WASHER
32	HANDLE
33	DIAL SCALE
34	LOCKING HANDLE KNOB
35	CALIBRATION LABEL
36	CONNECTION LOOP
37	GEAR SHAFT
38	INDICATOR
39	CLINCH BOLT

40	ROLL PIN
41	CROSS RECESS PAN HD SCREW
42	HOOP FOR KEY WRENCH
43	WARNING LABEL
44	ROLL PIN
45	HANDLE BELT TENSION
46	LOCKING HANDLE KNOB
47	CIRCLIP FOR BEARING
48	CIRCLIP FOR BEARING
49	ADJUSTING SHAFT
50	SLIP SHAFT
51	FLAT WASHER
52	FLAT WASHER
53	NUT
54	MOTOR CONNECTION PLATE
55	OUTSIDE HEX. BOLT
56	SPRING WASHER
57	NUT
58	MOTOR
59	HEX. SOC SET SCREW
60	MOTOR PULLEY
61	FLAT KEY
62	NUT
63	BELT
64	MICRO SWITCH ASSEMBLY
65	FLAT WASHER
66	SPRING WASHER
67	NUT
68	MICRO SWITCH PRESSING CLAW
69	FLAT WASHER
70	SPRING WASHER
71	NUT
72	CAM ASSEMBLY
73	CROSS RECESSED PAN HEAD SCREW
74	DAMPING WASHER
75	PROTECTOR RING
76	PULLEY COVER
77	FLAT WASHER
78	OUTSIDE HEX BOLT

79	CORD CLAMP
80	BIG FLAT WASHER
81	PULLEY COVER KNOB
82	ECCENTRIC SHAFT
83	MIDDLE PULLEY
84	BEARING
85	CIRCLIP FOR BEARING
86	BELT
87	PROTECTOR RING
88	CORD CLAMP
89	PLUG WITH CABLE
90	SPRING
91	SPRING COVER
92	MILLED NUT
93	BIG FLAT WASHER
94	HEX. SOC HD CAP SCREW
95	A WORD HEAD SCREW
96	HOUSING
97	SPINDLE PULLEY
98	FLAT KEY
99	KEYWAY SPINDLE
100	BEARING
101	BEARING RING
102	CIRCLIP FOR BEARING
103	SWITCH BOX
104	SWITCH
105	CROSS RECESS HEAD TAPPING SCREW
106	WASHER
107	SPINDLE SOCKET
108	BEARING
109	MAIN SPINDLE
110	TAPER CORE
111	CHUCK
112	CHUCK GUARD
113	THICK BRAKE IRON
114	HEXAGON BAR WRENCH
115	HEXAGON BAR WRENCH
116	HEXAGON BAR WRENCH
117	HEXAGON BAR WRENCH

118	HEX. SOC SET SCREW
119	HEX. SOC SET SCREW
120	CIRCLIP FOR BEARING
121	BEARING

EXPLODED DIAGRAM OF DRILL PRESS PD-510 ( D600 )

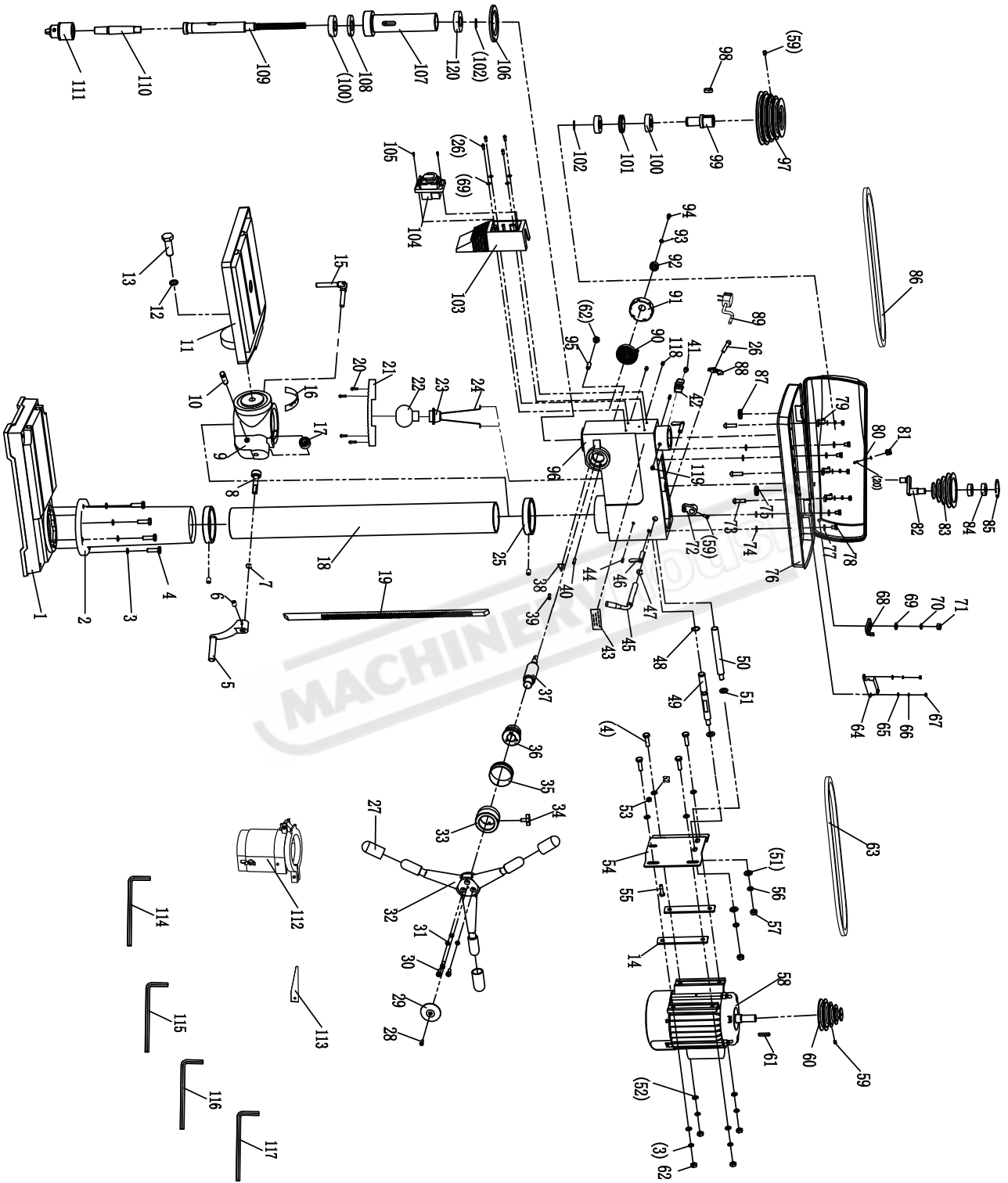

**EXPLODED DIAGRAM OF DRILL PRESS PD-510 ( D600 )**

1	BASE
2	COLUMN FLANGE
3	SPRING WASHER
4	OUTSIDE HEX. BOLT
5	CRANK
6	HEX. SOC SET SCREW
7	CIRCLIP FOR BEARING
8	WORM
9	TABLE SUPPORT
10	WORM PIN
11	WORKING TABLE
12	SPRING WASHER
13	OUTSIDE HEX. BOLT
14	RUBBER BLANKET
15	LOCKING HANDLE
16	ANGLE LABEL
17	WORM GEAR
18	COLUMN
19	RACK
20	CROSS RECESS PAN HD SCREW
21	LAMP-CHIMNEY
22	LAMP-BULB
23	LAMP-SOCKET
24	LAMP-BRACKET
25	COLLAR RACK
26	CROSS RECESS PAN HD SCREW
27	HANDLE SHEATH
28	CROSS RECESS COUNTERSUNK HD SCREW
29	CAP HANDLE
30	HEX. SOC HD CAP SCREW
31	SPRING WASHER
32	HANDLE
33	DIAL SCALE
34	LOCKING HANDLE KNOB
35	CALIBRATION LABEL
36	CONNECTION LOOP
37	GEAR SHAFT
38	INDICATOR
39	CLINCH BOLT

40	ROLL PIN
41	CROSS RECESS PAN HD SCREW
42	HOOP FOR KEY WRENCH
43	WARNING LABEL
44	ROLL PIN
45	HANDLE BELT TENSION
46	LOCKING HANDLE KNOB
47	CIRCLIP FOR BEARING
48	CIRCLIP FOR BEARING
49	ADJUSTING SHAFT
50	SLIP SHAFT
51	FLAT WASHER
52	FLAT WASHER
53	NUT
54	MOTOR CONNECTION PLATE
55	OUTSIDE HEX. BOLT
56	SPRING WASHER
57	NUT
58	MOTOR
59	HEX. SOC SET SCREW
60	MOTOR PULLEY
61	FLAT KEY
62	NUT
63	BELT
64	MICRO SWITCH ASSEMBLY
65	FLAT WASHER
66	SPRING WASHER
67	NUT
68	MICRO SWITCH PRESSING CLAW
69	FLAT WASHER
70	SPRING WASHER
71	NUT
72	CAM ASSEMBLY
73	CROSS RECESSED PAN HEAD SCREW
74	DAMPING WASHER
75	PROTECTOR RING
76	PULLEY COVER
77	FLAT WASHER
78	OUTSIDE HEX BOLT

79	CORD CLAMP
80	BIG FLAT WASHER
81	PULLEY COVER KNOB
82	ECCENTRIC SHAFT
83	MIDDLE PULLEY
84	BEARING
85	CIRCLIP FOR BEARING
86	BELT
87	PROTECTOR RING
88	CORD CLAMP
89	PLUG WITH CABLE
90	SPRING
91	SPRING COVER
92	MILLED NUT
93	BIG FLAT WASHER
94	HEX. SOC HD CAP SCREW
95	A WORD HEAD SCREW
96	HOUSING
97	SPINDLE PULLEY
98	FLAT KEY
99	KEYWAY SPINDLE
100	BEARING
101	BEARING RING
102	CIRCLIP FOR BEARING
103	SWITCH BOX
104	SWITCH
105	CROSS RECESS HEAD TAPPING SCREW
106	WASHER
107	SPINDLE SOCKET
108	BEARING
109	MAIN SPINDLE
110	TAPER SPINDLE
111	CHUCK
112	CHUCK GUARD
113	THICK BRAKE IRON
114	HEXAGON BAR WRENCH
115	HEXAGON BAR WRENCH
116	HEXAGON BAR WRENCH
117	HEXAGON BAR WRENCH

118	HEX. SOC SET SCREW
119	HEX. SOC SET SCREW
120	BEARING



# WARNING

## General Machinery Safety Instructions

---

Machinery House  
requires you to read this entire Manual before using this machine.

- 1. Read the entire Manual before starting machinery.** Machinery may cause serious injury if not correctly used.
- 2. Always use correct hearing protection when operating machinery.** Machinery noise may cause permanent hearing damage.
- 3. Machinery must never be used when tired, or under the influence of drugs or alcohol.** When running machinery you must be alert at all times.
- 4. Wear correct Clothing.** At all times remove all loose clothing, necklaces, rings, jewelry, etc. Long hair must be contained in a hair net. Non-slip protective footwear must be worn.
- 5. Always wear correct respirators around fumes or dust when operating machinery.** Machinery fumes & dust can cause serious respiratory illness. Dust extractors must be used where applicable.
- 6. Always wear correct safety glasses.** When machining you must use the correct eye protection to prevent injuring your eyes.
- 7. Keep work clean and make sure you have good lighting.** Cluttered and dark shadows may cause accidents.
- 8. Personnel must be properly trained or well supervised when operating machinery.** Make sure you have clear and safe understanding of the machine you are operating.
- 9. Keep children and visitors away.** Make sure children and visitors are at a safe distance for you work area.
- 10. Keep your workshop childproof.** Use padlocks, Turn off master power switches and remove start switch keys.
- 11. Never leave machine unattended.** Turn power off and wait till machine has come to a complete stop before leaving the machine unattended.
- 12. Make a safe working environment.** Do not use machine in a damp, wet area, or where flammable or noxious fumes may exist.
- 13. Disconnect main power before service machine.** Make sure power switch is in the off position before re-connecting.
- 14. Use correct amperage extension cords.** Undersized extension cords overheat and lose power. Replace extension cords if they become damaged.
- 15. Keep machine well maintained.** Keep blades sharp and clean for best and safest performance. Follow instructions when lubricating and changing accessories.
- 16. Keep machine well guarded.** Make sure guards on machine are in place and are all working correctly.
- 17. Do not overreach.** Keep proper footing and balance at all times.
- 18. Secure workpiece.** Use clamps or a vice to hold the workpiece where practical. Keeping the workpiece secure will free up your hand to operate the machine and will protect hand from injury.
- 19. Check machine over before operating.** Check machine for damaged parts, loose bolts, Keys and wrenches left on machine and any other conditions that may effect the machines operation. Repair and replace damaged parts.
- 20. Use recommended accessories.** Refer to instruction manual or ask correct service officer when using accessories. The use of improper accessories may cause the risk of injury.
- 21. Do not force machinery.** Work at the speed and capacity at which the machine or accessory was designed.
- 22. Use correct lifting practice.** Always use the correct lifting methods when using machinery. Incorrect lifting methods can cause serious injury.
- 23. Lock mobile bases.** Make sure any mobile bases are locked before using machine.
- 24. Allergic reactions.** Certain metal shavings and cutting fluids may cause an allergic reaction in people and animals, especially when cutting as the fumes can be inhaled. Make sure you know what type of metal and cutting fluid you will be exposed to and how to avoid contamination.
- 25. Call for help.** If at any time you experience difficulties, stop the machine and call you nearest branch service department for help.



# WARNING

## Drilling Machine Safety Instructions

---

Machinery House  
requires you to read this entire Manual before using this machine.

- 1. Maintenance.** Make sure the Drill is turned off and disconnect from the main power supply and make sure all moving parts have come to a complete stop before any inspection, adjustment or maintenance is carried out.
  - 2. Drill Condition.** Drill must be maintained for a proper working condition. Never operate a Drill that has damaged or worn parts. Scheduled routine maintenance should be performed on a scheduled basis.
  - 3. Leaving a Drill Unattended.** Always turn the Drill off and make sure all moving parts have come to a complete stop before leaving the Drill. Do not leave Drill running unattended for any reason.
  - 4. Avoiding Entanglement.** Remove loose clothing, belts, or jewelry items. Never wear gloves while machine is in operation. Tie up long hair and use the correct hair nets to avoid any entanglement with the Drill spindle or moving parts.
  - 5. Chuck key & wrench safety.** Always remove chuck keys, wrenches and any service tools immediately after use. Chuck keys left in the chuck can cause serious injury.
  - 6. Understand the machines controls.** Make sure you understand the use and operation of all controls.
  - 7. Drill bit selection.** Always use the correct Drill bit for the job you are Drilling. Make sure you use the correct shank drill bit for your drilling machine.
  - 8. Secure the Drill Bit.** Properly tighten and securely lock the drill bit in the chuck.
  - 9. Cutting Tool inspection.** Inspect Drill for sharpness, chips, or cracks before use. Replace any cutting tools immediately if dull, chipped or cracked. Handle new cutting tools with care. Cutting edges are very sharp and can cause lacerations.
  - 10. Reversing the spindle.** Make sure the spindle has come to a complete stop before changing the direction of the spindle.
  - 11. Stopping the spindle.** Do not slow or stop the spindle by using your hand.
  - 12. Speed selection.** Select the appropriate speed for the type of work, material, and tool bit. Allow the Drill to reach full speed before beginning a cut.
  - 13. Changing Belts for speed selection.** Always allow the machine to come to a complete stop and turn power off before changing belts. Not turning power off when changing belts can cause serious injury.
  - 14. Clearing chips.** Always use a brush to clear chips. Never clear chips when the drill is running.
  - 15. Power outage.** In the event of a power failure during use of the drill, turn off all switches to avoid possible sudden start up once power is restored.
  - 16. Clean work area.** Keep the area around the drill clean from oil, tools, chips.
  - 17. Surface/workpiece area.** Before turning the drill on, make sure the table is clear of any objects (tools, scraps, off-cuts etc.) Do not drill material that does not have a flat surface, unless a suitable support is used.
  - 18. Table Lock.** Make sure the table is tightened before starting the drill.
  - 19. For - Radial Drill Arm Lock.** Make sure the arm is locked before leaving or starting a radial arm drill. An unlocked radial drill arm can swing and cause serious injury.
  - 20. Drilling Sheet metal.** All sheet metal should be clamped to the table before drilling.
  - 21. Mounting workpieces.** Use clamps or vices to secure workpiece before drilling. Position work so you avoid drilling into table.
  - 22. Guarding.** Do not operate the drill when chuck guard is removed.
  - 23. Eye and hand protection.** A face shield with safety glasses is recommended. Always keep hands and fingers away from the drill bit. Never hold a workpiece in your hand while drilling. Do not wear gloves while operating the drill.
  - 24. Drill operation.** Never start the drill with the drill bit pressed against the workpiece. Feed the drill evenly into the workpiece. Back the drill out of deep holes. Turn the machine off and clear chips and scrap pieces with a brush. Turn power off, remove drill bit, and clean the table before leaving the machine.
  - 25. Call for help.** If at any time you experience difficulties, stop the machine and call your nearest branch service department for help.
-

# PLANT SAFETY PROGRAM

## NEW MACHINERY HAZARD IDENTIFICATION, ASSESSMENT & CONTROL

### Drilling Machine

Developed in Co-operation Between A.W.I.S.A and Australia Chamber of Manufactures  
This program is based upon the Safe Work Australia, Code of Practice - Managing Risks of Plant in the Workplace ( WHSA 2011 No10 )

Item No.	Hazard Identification	Hazard Assessment	Risk Control Strategies <small>(Recommended for Purchase / Buyer / User)</small>
A	ENTANGLEMENT	HIGH	Eliminate, avoid loose clothing / Long hair etc.
B	CRUSHING	LOW	Secure & support work material on drill table.
C	CUTTING, STABBING, PUNCTURING.	MEDIUM	Isolate power to machine prior to any checks or maintenance being carried out. Do not adjust or clean until the machine has fully stopped.
D	SHEARING	MEDIUM	Isolate power to machine when changing speeds or maintenance is being carried out. Make sure all guards are secured shut when machine is on.
F	STRIKING	MEDIUM	Ensure workpieces are tightly secured on machine. Wear safety glasses. For Radial Arm Drills ensure that arm is locked before drilling. Ensure correct spindle direction when drilling..
H	ELECTRICAL	MEDIUM	All electrical enclosures should only be opened with a tool that is not to be kept with the machine. Never clean or dust machine when power is on. Machine should be installed & checked by a Licensed Electrician.
M	HIGH TEMPERATURE	LOW	Wear appropriate protective clothing to prevent hot swarf.
O	OTHER HAZARDS, NOISE.	LOW	Wear hearing protection as required.

Plant Safety Program to be read in conjunction with manufactures instructions



[www.machineryhouse.com.au](http://www.machineryhouse.com.au)



[www.machineryhouse.co.nz](http://www.machineryhouse.co.nz)

Authorised and signed by:  
Safety officer:

  
.....  
Manager:

.....

Revised Date: 12th March 2012

## ADDITIONAL SHEET FOR PULLEY COVER LIFT KNOB

1. Please take out the pulley cover lift knob from the bag as Fig 1.
2. Please use a Phillips screw driver to tighten the screw as Fig 2 before operate the machine.

Fig 1



Fig 2



Fig 3



[www.machineryhouse.com.au](http://www.machineryhouse.com.au)



[www.machineryhouse.co.nz](http://www.machineryhouse.co.nz)